

# ISO 7241-1B HYDRAULIC INTERCHANGE QUICK COUPLING

PART NUMBER MALE DUST CAP	PRICE EACH
S19-2	5.36
S19-3	5.36
S19-4	5.36
S19-6	12.52
S19-8	16.34

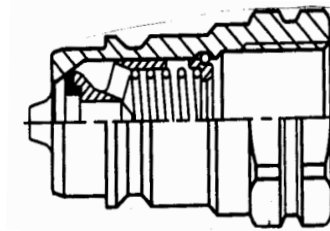
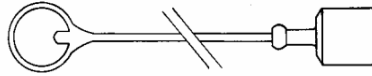

**MALE TIP STEEL**

PART NUMBER MALE TIP	THREAD SIZE FEMALE	WORKING PRESSURE (PSI)	RATED FLOW (GPM)	PARKER INTERCHANGE	AEROQUIP INTERCHANGE	PRICE EACH
S101-1	1/8" NPT	5000	1.5	H1-63	FD45-1002-02-02	9.43
S101-2	1/4" NPT	5000	4	H2-63	FD45-1002-04-04	8.06
S101-3	3/8" NPT	4500	7	H3-63	FD45-1002-06-06	12.61
S101-4	1/2" NPT	4000	12	H4-63	FD45-1002-08-08	11.02
S101-6	3/4" NPT	3500	28	H6-63	FD45-1002-06-06	20.97
S101-8	1" NPT	3000	50	H8-63	FD45-1002-08-08	39.67

PART NUMBER FEMALE DUST PLUG	PRICE EACH
S14-2	5.36
S14-3	5.36
S14-4	5.36
S14-6	12.52
S14-8	16.34

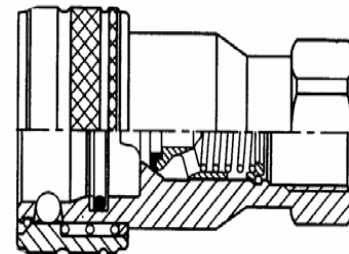
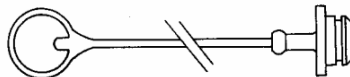

**FEMALE BODY STEEL**

PART NUMBER FEMALE BODY	THREAD SIZE FEMALE	WORKING PRESSURE (PSI)	RATED FLOW (GPM)	PARKER INTERCHANGE	AEROQUIP INTERCHANGE	PRICE EACH
S105-1	1/8" NPT	5000	1.5	H1-62	FD45-1003-02-02	18.57
S105-2	1/4" NPT	5000	4	H2-62	FD45-1003-04-04	17.11
S105-3	3/8" NPT	4500	7	H3-62	FD45-1003-06-06	25.34
S105-4	1/2" NPT	4000	12	H4-62	FD45-1003-08-08	35.82
S105-6	3/4" NPT	3500	28	H6-62	FD45-1003-06-06	56.31
S105-8	1" NPT	3000	50	H8-62	FD45-1003-08-08	92.31

## ISO 7241-1B HYDRAULIC INTERCHANGE QUICK COUPLING

PART NUMBER MALE DUST CAP	PRICE EACH
S19-2	5.36
S19-3	5.36
S19-4	5.36
S19-6	12.52
S19-8	16.34

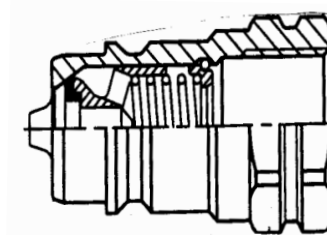
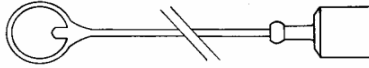

**MALE TIP BRASS**

PART NUMBER MALE TIP	THREAD SIZE FEMALE	WORKING PRESSURE (PSI)	RATED FLOW (GPM)	PARKER INTERCHANGE	AEROQUIP INTERCHANGE	PRICE EACH
BS101-1	1/8" NPT	3000	1	BH1-61	FD45-1092-02-02	9.82
BS101-2	1/4" NPT	3700	4	BH2-61	FD45-1092-04-04	11.67
BS101-3	3/8" NPT	2700	7	BH3-61	FD45-1092-06-06	14.62
BS101-4	1/2" NPT	3500	12	BH4-61	FD45-1092-08-10	18.19
BS101-6	3/4" NPT	2200	28	BH6-61	FD45-1092-12-12	33.87
BS101-8	1" NPT	1500	50	BH8-61	FD45-1092-16-16	60.83

PART NUMBER FEMALE DUST PLUG	PRICE EACH
S14-2	5.36
S14-3	5.36
S14-4	5.36
S14-6	12.52
S14-8	16.34

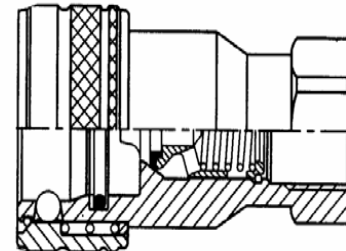
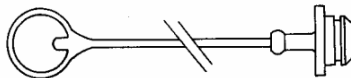

**FEMALE BODY BRASS**

PART NUMBER FEMALE BODY	THREAD SIZE FEMALE	WORKING PRESSURE (PSI)	RATED FLOW (GPM)	PARKER INTERCHANGE	AEROQUIP INTERCHANGE	PRICE EACH
BS105-1	1/8" NPT	3000	1	BH1-60	FD45-1091-02-02	25.69
BS105-2	1/4" NPT	3700	4	BH2-60	FD45-1091-04-04	30.81
BS105-3	3/8" NPT	2700	7	BH3-60	FD45-1091-06-06	44.28
BS105-4	1/2" NPT	3500	12	BH4-60	FD45-1091-08-10	57.73
BS105-6	3/4" NPT	2200	28	BH6-60	FD45-1091-12-12	110.54
BS105-8	1" NPT	1500	50	BH8-60	FD45-1091-16-16	178.09

# ISO 7241 A HYDRAULIC INTERCHANGE QUICK COUPLING

PART NUMBER MALE DUST CAP	PRICE EACH
S59-2	4.17
S59-3	4.17
S59-4	4.17
S59-6	5.56
S59-8	9.85

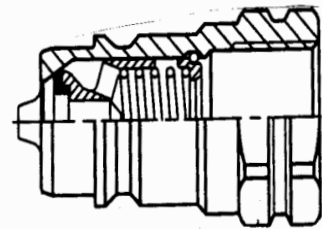
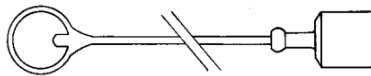

**MALE TIP STEEL**

PART NUMBER MALE TIP	THREAD SIZE FEMALE	WORKING PRESSURE (PSI)	RATED FLOW (GPM)	PARKER INTERCHANGE	AEROQUIP INTERCHANGE	PRICE EACH
S561-2	1/4" NPT	5000	3	6602-4-4	5602-4-4S	7.28
S561-3	3/8" NPT	4000	7	6602-6-6	5602-6-6S	9.34
S561-4	1/2" NPT	4000	12	6602-8-10	5602-8-10S	9.02
S561-4-8	3/4"-16 ORB	4000	12	6610-8-10	5610-8-10S	9.02
S561-6	3/4" NPT	4000	28	6602-12-12	5602-12-12S	19.45
S561-8	1" NPT	4000	50	6602-16-16	5602-16-16S	43.26
S561-10	1 1/4" NPT	3600	80			91.38
S561-12	1 1/2" NPT	3000	120			102.68
S561-16	2" NPT	2750	150			285.13

PART NUMBER FEMALE DUST PLUG	PRICE EACH
S54-2	4.17
S54-3	4.17
S54-4	4.17
S54-6	5.56
S54-8	9.09

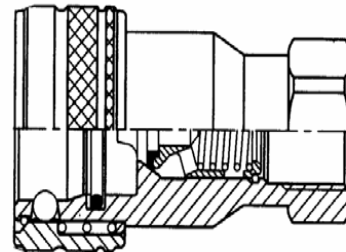
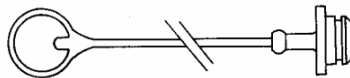

**FEMALE BODY STEEL**

PART NUMBER FEMALE BODY	THREAD SIZE FEMALE	WORKING PRESSURE (PSI)	RATED FLOW (GPM)	PARKER INTERCHANGE	AEROQUIP INTERCHANGE	PRICE EACH
S565-2	1/4" NPT	5000	3	6601-4-4	5601-4-4S	14.85
S565-3	3/8" NPT	4000	7	6601-6-6	5601-6-6S	18.49
S565-4	1/2" NPT	4000	12	6601-8-10	5601-8-10S	22.13
S565-4-8	3/4"-16 ORB	4000	12	6608-8-10	5608-8-10S	22.13
S565-6	3/4" NPT	4000	28	6601-12-12	5602-12-12S	37.47
S565-8	1" NPT	4000	50	6601-16-16	5602-16-16S	74.48
S565-10	1 1/4" NPT	3600	80			182.41
S565-12	1 1/2" NPT	3000	120			210.97
S565-16	2" NPT	2750	150			421.71

# ISO 16028 FLUSH FACE HYDRAULIC QUICK COUPLINGS

FE series quick coupling's are manufactured to the new ISO 16028 standard and are interchangeable with other couplings manufactured to the same norm. These couplings are manufactured from specialty steels and all wear surfaces are induction hardened . 5000 PSI is the maximum operating pressure across all sizes with a 4 to 1 safety factor . No spill design with high pressure , high flow rates and low pressure drops make this coupling very suitable for a wide range of applications.

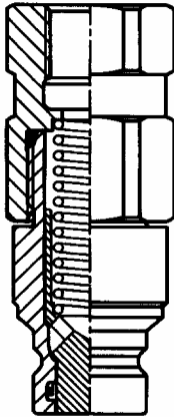

PART NUMBER MALE TIP	THREAD SIZE FEMALE	WORKING PRESSURE (PSI)	RATED FLOW (GPM)	PRICE EACH
FE491-1-2 FP	1/8" NPT	5000	1.5	29.35
FE491-2-4 FP	1/4" NPT	5000	5	29.35
FE491-3-6 FP	3/8" NPT	5000	10	33.88
FE491-3-8 FP	1/2" NPT	5000	10	34.09
FE491-4-8 FP	1/2" NPT	5000	20	49.13
FE491-4-10 FO	7/8"- 14 ORB	5000	20	97.12
FE491-4-12 FO	1-1/16-12 ORB	5000	20	43.76
FE491-4-12 FP	3/4" NPT	5000	20	48.32
FE491-5-10 FO	7/8"- 14 ORB	5000	26	51.62
FE491-5-12 FO	1-1/16-12 ORB	5000	26	51.62
FE491-5-12 FP	3/4" NPT	5000	26	61.18
FE491-6-12 FP	3/4" NPT	5000	36	114.84
FE491-6-16 FO	1-5/16-12 ORB	5000	36	119.75
FE491-6-16 FP	1" NPT	5000	36	122.54
FE491-8-20 FO	1-5/8-12 ORB	5000	52	184.84
FE491-8-20 FP	1-1/4" NPT	5000	52	184.84

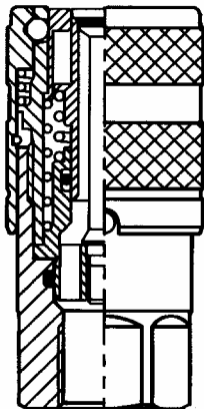

PART NUMBER FEMALE BODY	THREAD SIZE FEMALE	WORKING PRESSURE (PSI)	RATED FLOW (GPM)	PRICE EACH
FE495-1-2 FP	1/8" NPT	5000	1.5	56.86
FE495-2-4 FP	1/4" NPT	5000	5	56.86
FE495-3-6 FP	3/8" NPT	5000	10	67.32
FE495-3-8 FP	1/2" NPT	5000	10	67.78
FE495-4-8 FP	1/2" NPT	5000	20	96.20
FE495-4-10 FO	7/8"- 14 ORB	5000	20	102.76
FE495-4-12 FO	1-1/16-12 ORB	5000	20	85.69
FE495-4-12 FP	3/4" NPT	5000	20	94.64
FE495-5-10 FO	7/8"- 14 ORB	5000	26	114.19
FE495-5-12 FO	1-1/16-12 ORB	5000	26	114.19
FE495-5-12 FP	3/4" NPT	5000	26	135.33
FE495-6-12 FP	3/4" NPT	5000	36	210.74
FE495-6-16 FO	1-5/16-12 ORB	5000	36	224.26
FE495-6-16 FP	1" NPT	5000	36	196.67
FE495-8-20 FO	1-5/8-12 ORB	5000	52	297.67
FE495-8-20 FP	1-1/4" NPT	5000	52	297.67

# ISO 16028 FLUSH FACE HYDRAULIC QUICK COUPLINGS

FE series quick coupling's are manufactured to the new ISO 16028 standard and are interchangeable with other couplings manufactured to the same norm. These couplings are manufactured from specialty steels and all wear surfaces are induction hardened . 5000 PSI is the maximum operating pressure across all sizes with a 4 to 1 safety factor . No spill design with high pressure , high flow rates and low pressure drops make this coupling very suitable for a wide range of applications. The 492 Series connects under pressure up to 3,600 PSI.

## Connect Under Pressure

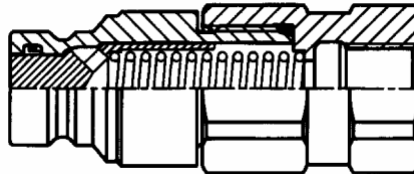

PART NUMBER	THREAD SIZE FEMALE	WORKING PRESSURE (PSI)	MAX CONNECT PRESSURE	RATED FLOW (GPM)	PRICE EACH
FE492-3-6 FP	3/8" NPT	5000	3600	10	60.66
FE492-3-8 FP	1/2" NPT	5000	3600	10	60.66
FE492-4-12 FO	1-1/16-12 ORB	5000	3600	20	139.47
FE492-4-12 FP	3/4" NPT	5000	3600	20	142.43
FE492-6-16 FO	1-5/16-12 ORB	5000	3600	36	466.93
FE492-6-16 FP	1" NPT	5000	3600	36	466.93

PART NUMBER MALE DUST CAP	PRICE EACH
FE409-2	5.43
FE409-3	4.08
FE409-4	3.36
FE409-6	5.43

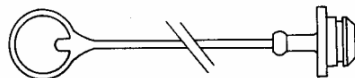
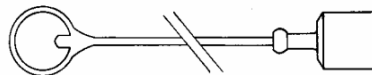

PART NUMBER FEMALE DUST PLUG	PRICE EACH
FE404-2	5.43
FE404-3	4.08
FE404-4	3.36
FE404-6	5.43

# HTMA HYDRAULIC INTERCHANGE QUICK COUPLING

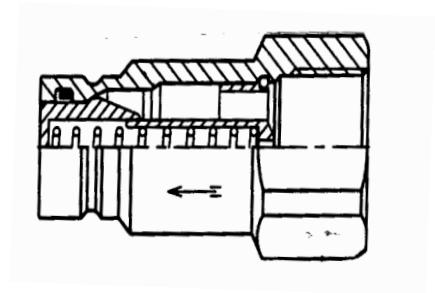

**MALE TIP STEEL**

PART NUMBER MALE TIP		WORKING PRESSURE (PSI)	RATED FLOW (GPM)	PARKER INTERCHANGE	AEROQUIP INTERCHANGE	PRICE EACH
FF491-3	3/8" NPT	3600	10	FF-372-6FP	FD49-1002-06-06	27.94
FF491-4	1/2" NPT	3600	10	FF-372-8FP	FD49-1002-08-06	27.94

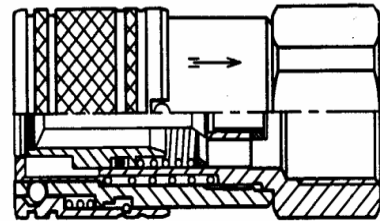

**FEMALE BODY STEEL**

PART NUMBER FEMALE BODY		WORKING PRESSURE (PSI)	RATED FLOW (GPM)	PARKER INTERCHANGE	AEROQUIP INTERCHANGE	PRICE EACH
FF495-3	3/8" NPT	3600	10	FF-371-6FP	FD49-1001-06-06	53.36
FF495-4	1/2" NPT	3600	10	FF-371-8FP	FD49-1001-08-06	53.36

**10,000 PSI PINE STYLE HYDRAULIC INTERCHANGE QUICK COUPLING**

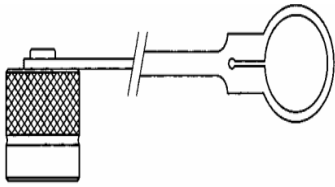

MALE DUST CAP STEEL	PRICE EACH
S39-3	11.98

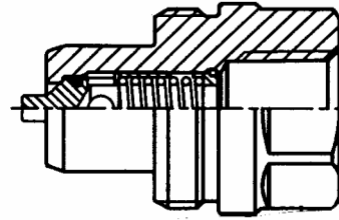

**MALE TIP STEEL**

PART NUMBER FEMALE BODY	THREAD SIZE FEMALE	WORKING PRESSURE (PSI)	RATED FLOW (GPM)	SAFEWAY INTERCHANGE	AEROQUIP INTERCHANGE	PRICE EACH
S31-2P	1/4" NPT	10000	6	S31-2P	N/A	13.32
S31-3P	3/8" NPT	10000	6	S31-3P	N/A	15.16

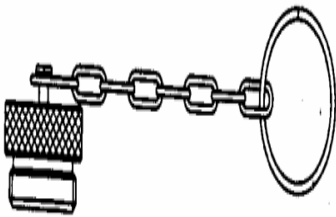

FEMALE DUST PLUG STEEL	PRICE EACH
S34-3	10.52

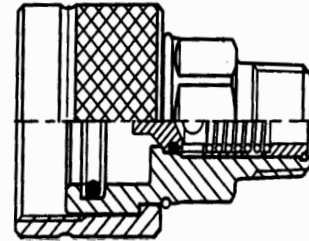

**FEMALE BODY STEEL**

PART NUMBER FEMALE BODY	THREAD SIZE MALE	WORKING PRESSURE (PSI)	RATED FLOW (GPM)	SAFEWAY INTERCHANGE	AEROQUIP INTERCHANGE	PRICE EACH
S35-2P	1/4" NPT	10000	6	S35-2P	N/A	22.38
S35-3P	3/8" NPT	10000	6	S35-3P	N/A	25.62

## 10,000 PSI BALL STYLE HYDRAULIC INTERCHANGE QUICK COUPLING

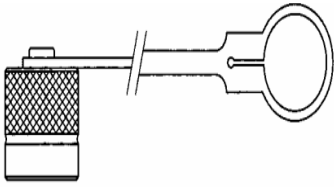

MALE DUST CAP STEEL	PRICE EACH
S39-3	11.98

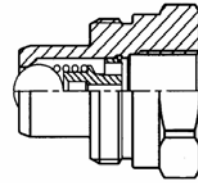

**MALE TIP STEEL**

PART NUMBER	THREAD SIZE FEMALE	WORKING PRESSURE (PSI)	RATED FLOW (GPM)	PARKER INTERCHANGE	AEROQUIP INTERCHANGE	PRICE EACH
S31-2B	1/4" NPT	10000	6	3010-2	N/A	13.68
S31-3B	3/8" NPT	10000	6	3010-3	N/A	13.68

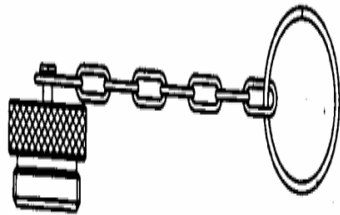

FEMALE DUST PLUG STEEL	PRICE EACH
S34-3	10.52

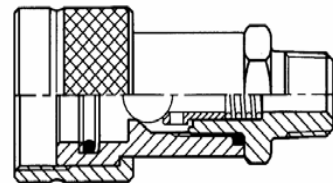

**FEMALE BODY STEEL**

PART NUMBER	THREAD SIZE MALE	WORKING PRESSURE (PSI)	RATED FLOW (GPM)	PARKER INTERCHANGE	AEROQUIP INTERCHANGE	PRICE EACH
S35-2B	1/4" NPT	10000	6	3050-2	N/A	25.96
S35-3B	3/8" NPT	10000	6	3050-3	N/A	23.55

**ISO 7241 AGRICULTURAL HYDRAULIC INTERCHANGE QUICK COUPLING**

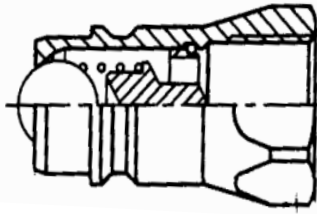

**MALE TIP BALL  
S71-4**

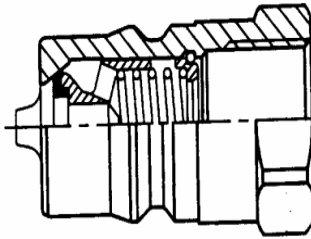

**MALE TIP PINE  
S71-4P**

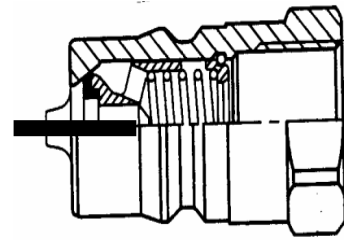

**MALE TIP PINE  
DECOMPRESSION  
CONECT UNDER  
PRESSURE  
S71-4PB**



MALE DUST CAP	PRICE EACH
S49-4	4.17

PART NUMBER MALE TIP	THREAD SIZE MALE	WORKING PRESSURE (PSI)	RATED FLOW (GPM)	PARKER PIONEER INTERCHANGE	SAFETYWAY INTERCHANGE	PRICE EACH
S71-4	1/2" NPT	3000	12	8010-4	S71-4	11.62
S71-4P	1/2" NPT	3000	12	8010-4P	S71-4P	8.95
S71-4PB	1/2" NPT	3000	12	8010-4P-DC		11.16

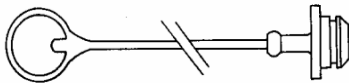

FEMALE DUST PLUG	PRICE EACH
S44-4	4.17

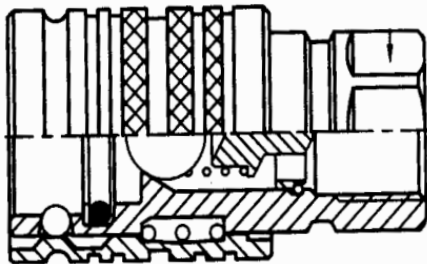
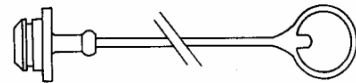

**FEMALE BODY STEEL  
PINE TYPE  
S45-4P**

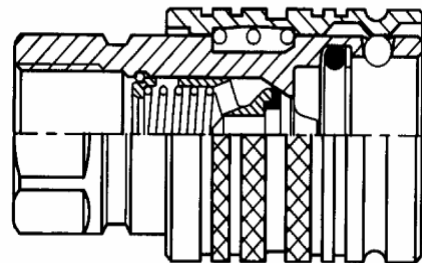

**FEMALE BODY STEEL  
BALL TYPE  
S45-4**

PART NUMBER FEMALE BODY	THREAD SIZE MALE	WORKING PRESSURE (PSI)	RATED FLOW (GPM)	PARKER PIONEER INTERCHANGE	SAFETYWAY INTERCHANGE	PRICE EACH
S45-4	1/2" NPT	3000	12	4200-4	S45-4	24.90
S45-4P	1/2" NPT	3000	12	4200-4P	S45-4P	25.50

# AGRICULTURAL INTERCHANGE QUICK COUPLER

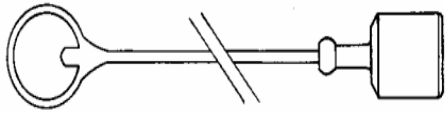

MALE DUST CAP	PRICE EACH
S49-2	4.17
S49-3	4.17

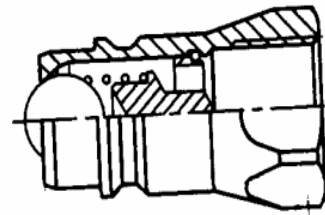

**MALE TIP**

PART NUMBER MALE TIP	THREAD SIZE MALE	WORKING PRESSURE (PSI)	RATED FLOW (GPM)	PARKER PIONEER INTERCHANGE	SAFEWAY INTERCHANGE	PRICE EACH
S41-2	1/4" NPT	3000	3	4010-2	S41-2	8.21
S41-3	3/8" NPT	3000	6	4010-3	S41-3	10.49
S21-8P	1" NPT	3000	50	N/A	N/A	47.46



FEMALE DUST PLUG	PRICE EACH
S44-2	5.39
S44-3	4.17

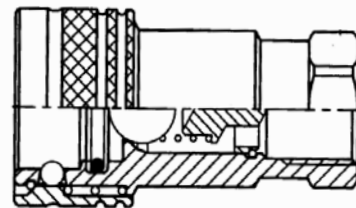

**FEMALE BODY**

PART NUMBER FEMALE BODY	THREAD SIZE MALE	WORKING PRESSURE (PSI)	RATED FLOW (GPM)	PARKER PIONEER INTERCHANGE	SAFEWAY INTERCHANGE	PRICE EACH
S45-2	1/4" NPT	3000	3	4050-2	S25A-2	18.32
S45-3	3/8" NPT	3000	6	4050-3	N/A	22.62
S25-8P	1" NPT	3000	50	N/A	N/A	89.06

## WING NUT HYDRAULIC QUICK COUPLING

PART NUMBER PLUG DUST COVER	PRICE EACH
SF-12	36.93
SF-16	43.80
SF-20	71.29
SF-24	91.62

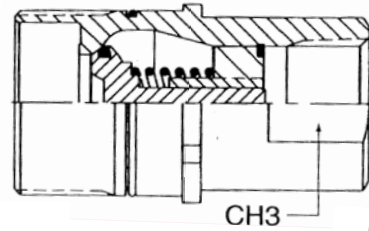
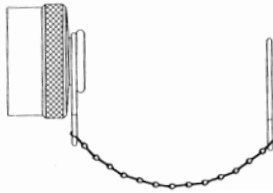

**BRASS PLUG**

PART NUMBER MALE PLUG	THREAD SIZE FEMALE	WORKING PRESSURE (PSI)	RATED FLOW (GPM)	PARKER INTERCHANGE	AEROQUIP INTERCHANGE	PRICE EACH
S511-08	1/2" NPT	3000	7	6105-08	5100S2-10B	94.63
S511-12	3/4" NPT	3000	18	6105-12	5100S2-12B	63.86
S511-16	1" NPT	3000	40	6105-16	5100S2-16B	77.61
S511-20	1 1/4" NPT	2750	75	6105-20	5100S2-20B	180.04
S511-24	1 1/2" NPT	2500	100	6105-24	5100S2-24B	280.86

PART NUMBER FEMALE DUST PLUG	PRICE EACH
SM-12	41.66
SM-16	46.38
SM-20	73.01
SM-24	105.22

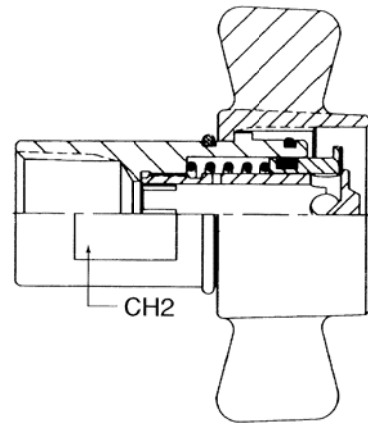
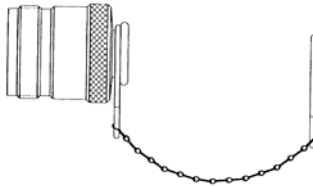

**BRASS COUPLER**

PART NUMBER FEMALE BODY	THREAD SIZE FEMALE	WORKING PRESSURE (PSI)	RATED FLOW (GPM)	PARKER INTERCHANGE	AEROQUIP INTERCHANGE	PRICE EACH
S515-08	1/2" NPT	3000	7	6125-08	5100S5-10B	104.39
S515-12	3/4" NPT	3000	18	6125-12	5100S5-12B	93.33
S515-16	1" NPT	3000	40	6125-16	5100S5-16B	115.44
S515-20	1 1/4" NPT	2750	75	6125-20	5100S5-20B	203.74
S515-24	1 1/2" NPT	2500	100	6125-24	5100S5-24B	304.31