

<b>PART NO.</b>	<b>NET PART EACH</b>	<b>NO.</b>	<b>NET PART EACH</b>	<b>NO.</b>	<b>NET PART EACH</b>	<b>NO.</b>		
 <p><b>CAP NUT</b></p>			 <p><b>TUBE SLEEVE</b></p>			 <p><b>(1) MALE ORFS (2) MALE ORFS</b></p>		
FF304-C-4	2.23		FF319-4	0.76	FF2403-4-4	4.33		
FF304-C-6	2.48		FF319-6	0.70	FF2403-6-4	5.79		
FF304-C-8	3.35		FF319-8	1.03	FF2403-6-6	5.46		
FF304-C-10	4.33		FF319-10	1.03	FF2403-8-6	6.92		
FF304-C-12	5.82		FF319-12	3.03	FF2403-8-8	5.79		
FF304-C-16	8.71		FF319-16	2.76	FF2403-10-8	9.52		
FF304-C-20	12.66		FF319-20	4.33	FF2403-10-10	6.76		
FF304-C-24	28.88		FF319-24	11.63	FF2403-12-8	18.93		
 <p><b>BULKHEAD LOCK NUT</b></p>			 <p><b>(1) BORE (2) MALE ORFS</b></p>			 <p><b>(1) MALE ORFS (2) MALE PIPE</b></p>		
FF306-4	0.49		FF403-10-10	5.57	FF2404-4-2	2.10		
FF306-6	1.57		FF403-12-12	6.38	FF2404-4-4	2.35		
FF306-8	1.84		FF403-16-12	14.12	FF2404-4-6	4.16		
FF306-10	2.27		FF403-16-16	9.63	FF2404-6-2	4.38		
FF306-12	2.92		FF403-20-20	14.12	FF2404-6-4	2.48		
FF306-16	3.30				FF2404-6-6	2.13		
FF306-20	4.49				FF2404-6-8	4.38		
 <p><b>TUBE NUT</b></p>					FF2404-8-6	4.11		
FF318-4	1.14				FF2404-8-8	2.80		
FF318-6	1.24				FF2404-8-12	5.52		
FF318-8	1.78				FF2404-10-8	5.57		
FF318-10	2.54				FF2404-12-8	7.25		
FF318-12	3.97				FF2404-12-12	7.52		
FF318-16	5.79				FF2404-12-16	12.66		
FF318-20	9.48				FF2404-16-12	12.41		
FF318-24	13.41				FF2404-16-16	8.87		
					FF2404-20-16	19.74		
					FF2404-20-20	12.73		
					FF2404-24-24	28.88		

PART NO.	NET PART EACH	PART NO.	NET PART EACH	PART NO.	NET PART EACH
----------	---------------	----------	---------------	----------	---------------

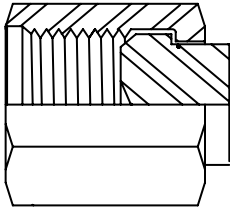
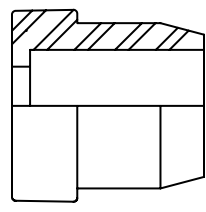
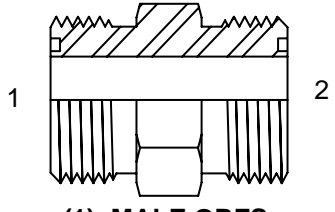
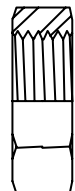
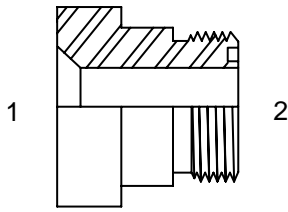
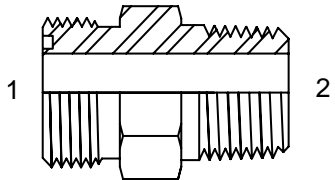
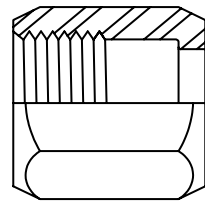
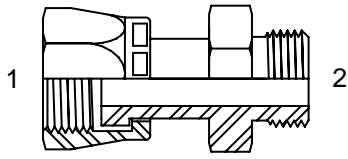

**(1) ORFS FEMALE SWIVEL  
(2) MALE ORFS**

FF2406-6-4	8.71
FF2406-8-4	12.01
FF2406-8-6	8.82
FF2406-10-4	11.79
FF2406-10-6	15.20
FF2406-10-8	14.76
FF2406-12-4	19.90
FF2406-12-6	19.74
FF2406-12-8	15.25
FF2406-12-10	14.93
FF2406-16-8	29.31
FF2406-16-10	38.67
FF2406-16-12	25.31
FF2406-20-12	44.94
FF2406-20-16	40.40
FF2406-24-16	47.49
FF2406-24-20	58.37

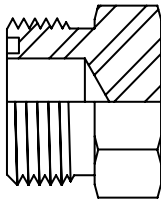

**ORFS PLUG**

FF2408-4	2.49
FF2408-6	2.51
FF2408-8	2.93
FF2408-10	4.99
FF2408-12	5.46
FF2408-16	8.14
FF2408-20	20.39
FF2408-24	22.07

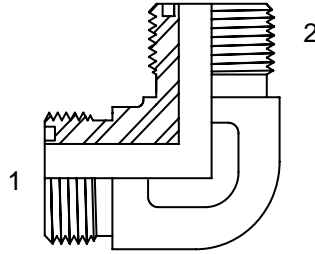

**(1) MALE ORFS  
(2) MALE PIPE**

FF2500-4-4	7.52
FF2500-6-6	8.98
FF2500-8-8	9.36
FF2500-10-10	13.63
FF2500-12-12	21.04
FF2500-16-16	28.61
FF2500-20-20	56.52
FF2500-24-24	84.04

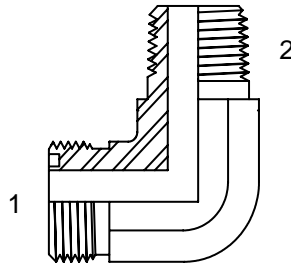

**(1) MALE ORFS  
(2) MALE PIPE**

FF2501-4-2	7.25
FF2501-4-4	6.38
FF2501-4-6	8.33
FF2501-6-4	6.59
FF2501-6-6	7.95
FF2501-6-8	9.90
FF2501-8-6	9.14
FF2501-8-8	10.01
FF2501-10-8	14.55
FF2501-10-12	14.49
FF2501-12-8	16.17
FF2501-12-12	16.26
FF2501-12-16	25.96
FF2501-16-12	24.23
FF2501-16-16	36.30
FF2501-20-20	44.76
FF2501-24-24	62.19

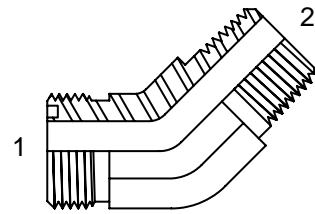

**(1) MALE ORFS  
(2) MALE PIPE**

FF2503-6-6	7.52
FF2503-8-6	8.55
FF2503-8-8	8.60
FF2503-10-8	11.19
FF2503-12-12	14.00
FF2503-16-16	19.85

<b>PART NO.</b>	<b>NET PART EACH NO.</b>	<b>NET PART EACH NO.</b>	<b>NET PART EACH</b>
-----------------	--------------------------	--------------------------	----------------------

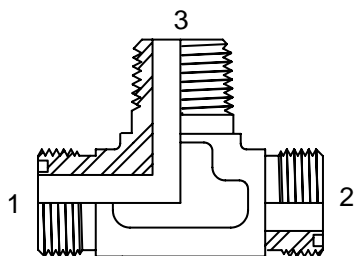

**(1) (2) MALE ORFS  
(3) MALE PIPE**

FF2601-4-4	17.58
FF2601-6-4	20.45
FF2601-6-6	30.47
FF2601-8-6	34.20
FF2601-8-8	21.88
FF2601-12-12	41.96
FF2601-16-16	66.22
FF2601-20-20	88.29

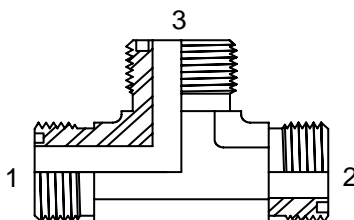

**(1)(2)(3) MALE ORFS**

FF2603-4	12.33
FF2603-6	11.61
FF2603-8	15.25
FF2603-10	16.12
FF2603-12	24.28
FF2603-16	31.34
FF2603-20	69.77

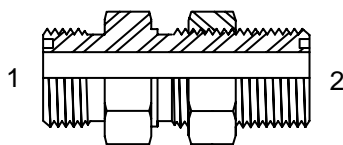

**(1) MALE ORFS  
(2) ORFS BULKHEAD**

FF2700-4-4	8.24
FF2700-6-6	7.99
FF2700-8-8	9.80
FF2700-10-10	17.09
FF2700-12-12	17.82
FF2700-16-16	33.09
FF2700-20-20	47.38

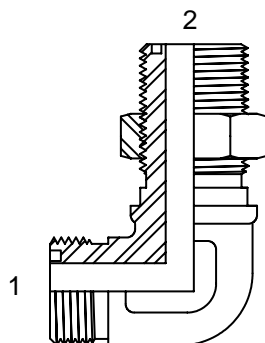

**(1) MALE ORFS  
(2) ORFS BULKHEAD**

FF2701-4-4	9.57
FF2701-6-6	11.14
FF2701-8-8	13.80
FF2701-10-10	22.39
FF2701-12-12	26.07
FF2701-16-16	32.55
FF2701-20-20	77.06

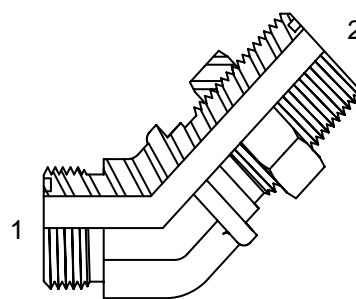

**(1) MALE ORFS  
(2) ORFS BULKHEAD**

FF2702-4-4	9.57
FF2702-6-6	13.47
FF2702-8-8	15.63
FF2702-12-12	28.99
FF2702-16-16	38.72

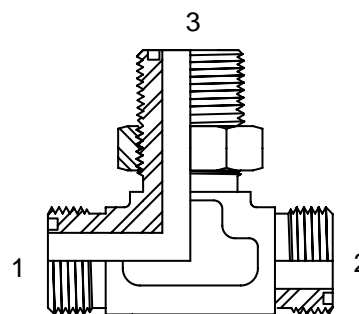

**(1) (2) MALE ORFS  
(3) ORFS BULKHEAD**

FF2703-4-4	15.73
FF2703-6-6	19.25
FF2703-8-8	21.03
FF2703-10-10	32.96
FF2703-12-12	35.80

<b>PART NO.</b>	<b>NET PART EACH NO.</b>	<b>NET PART EACH NO.</b>	<b>NET PART EACH NO.</b>
-----------------	--------------------------	--------------------------	--------------------------

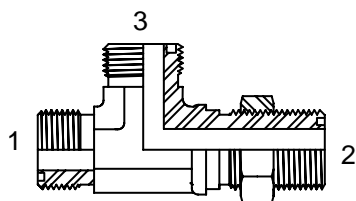

**(1) (3) MALE ORFS  
(2) ORFS BULKHEAD**

FF2704-4-4	13.46
FF2704-6-6	17.53
FF2704-8-8	19.58
FF2704-10-10	33.34
FF2704-12-12	36.23
FF2704-16-16	53.81

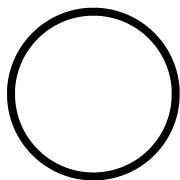

**FLAT FACE "BUNA-N"  
"O" RING**

FF4000-4	0.64
FF4000-6	0.64
FF4000-8	0.64
FF4000-10	0.64
FF4000-12	0.64
FF4000-16	0.64
FF4000-20	0.64

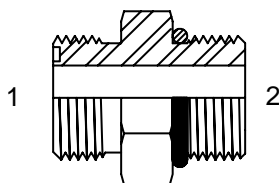

**(1) MALE ORFS  
(2) MALE O-RING**

FF6400-4-4	2.38
FF6400-4-5	7.79
FF6400-4-6	3.69
FF6400-4-8	6.06
FF6400-6-4	3.44
FF6400-6-6	2.42
FF6400-6-8	3.37
FF6400-6-10	4.87
FF6400-8-6	3.50
FF6400-8-8	3.63
FF6400-8-10	3.75
FF6400-8-12	7.09
FF6400-8-16	11.84
FF6400-10-8	4.99
FF6400-10-10	3.91
FF6400-10-12	7.60
FF6400-12-8	7.83
FF6400-12-10	4.99
FF6400-12-12	4.80
FF6400-12-16	9.58
FF6400-16-12	9.23
FF6400-16-16	7.51
FF6400-16-20	14.98
FF6400-20-16	21.25
FF6400-20-20	18.26
FF6400-20-24	19.66
FF6400-24-20	30.64
FF6400-24-24	33.94

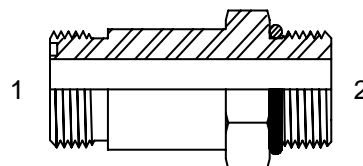

**(1) MALE ORFS LONG  
(2) MALE O-RING**

FF6400-L-4-4	8.76
FF6400-L-6-6	5.62
FF6400-L-8-8	16.19
FF6400-L-10-10	21.90
FF6400-L-12-12	30.29
FF6400-L-16-16	45.16

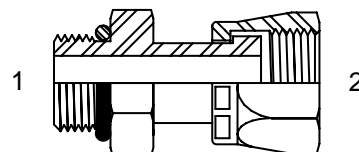

**(1) MALE O-RING  
(2) ORFS FEMALE SWIVEL**

FF6402-04-04	9.09
FF6402-06-06	9.41
FF6402-08-08	11.79
FF6402-10-10	13.84
FF6402-12-12	16.12
FF6402-16-16	30.50
FF6402-20-20	41.91

**PART  
NO.**

**NET PART  
EACH NO.**

**NET PART  
EACH NO.**

**NET  
EACH**

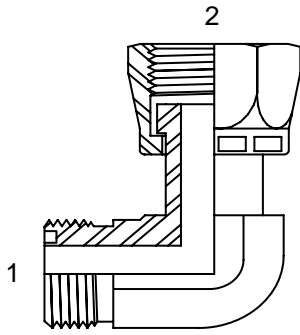

**(1) MALE ORFS  
(2) ORFS FEMALE SWIVEL**

FF6500-4-4	8.76
FF6500-6-6	9.68
FF6500-8-8	11.36
FF6500-10-10	15.03
FF6500-12-12	16.19
FF6500-16-16	29.15
FF6500-20-20	60.57
FF6500-24-24	91.67

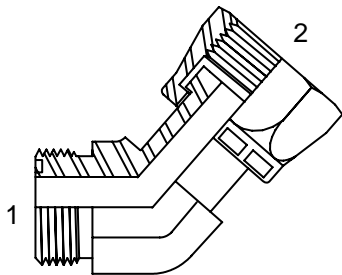

**(1) MALE FLAT FACE  
(2) ORFS FEMALE SWIVEL**

FF6502-4-4	10.98
FF6502-6-6	11.09
FF6502-8-8	14.55
FF6502-10-10	17.79
FF6502-12-12	25.15
FF6502-16-16	39.26
FF6502-20-20	64.09

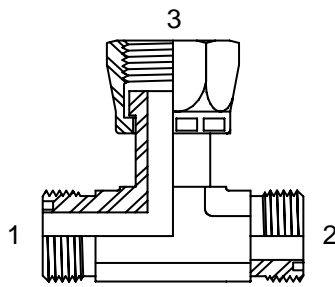

**(1) (2) MALE ORFS  
(3) ORFS SWIVEL**

FF6600-4-4	14.98
FF6600-6-6	14.44
FF6600-8-8	18.17
FF6600-10-10	26.77
FF6600-12-12	36.88
FF6600-16-16	45.54
FF6600-20-20	90.86
FF6600-24-24	142.51

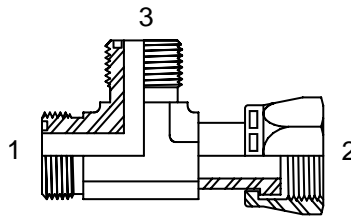

**(1) (3) MALE ORFS  
(2) ORFS FEMALE SWIVEL**

FF6602-4-4	14.17
FF6602-6-6	12.03
FF6602-8-8	13.36
FF6602-10-10	21.47
FF6602-12-12	28.93
FF6602-16-16	45.02
FF6602-20-20	87.71

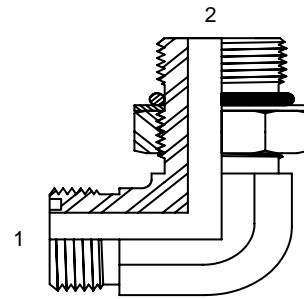

**(1) MALE ORFS  
(2) ADJ. O-RING**

FF6801-4-4	7.90
FF6801-4-6	9.90
FF6801-4-8	19.58
FF6801-6-4	9.46
FF6801-6-6	8.60
FF6801-6-8	12.38
FF6801-6-10	26.93
FF6801-8-6	13.95
FF6801-8-8	10.02
FF6801-8-10	13.57
FF6801-8-12	20.39
FF6801-10-8	14.17
FF6801-10-10	14.01
FF6801-10-12	20.44
FF6801-12-10	21.52
FF6801-12-12	15.30
FF6801-12-16	28.15
FF6801-16-12	50.71
FF6801-16-16	21.16
FF6801-16-20	44.86
FF6801-20-16	48.35
FF6801-20-20	36.87
FF6801-20-24	92.97
FF6801-24-24	61.08

**PART  
NO.**

**NET PART  
EACH NO.**

**NET PART  
EACH NO.**

**NET  
EACH**

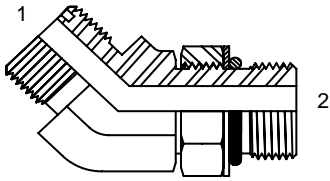

**(1) MALE ORFS  
(2) ADJ. O-RING**

FF6802-4-4	10.38
FF6802-4-6	13.20
FF6802-6-4	13.95
FF6802-6-6	10.60
FF6802-6-8	14.49
FF6802-8-6	14.49
FF6802-8-8	12.60
FF6802-8-10	16.77
FF6802-10-8	16.49
FF6802-10-10	16.12
FF6802-10-12	25.53
FF6802-12-10	24.99
FF6802-12-12	20.23
FF6802-12-16	34.04
FF6802-16-12	33.37
FF6802-16-16	25.83
FF6802-20-20	50.52

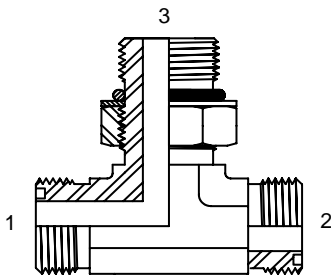

**(1) (2) MALE ORFS  
(3) ADJ. O-RING**

FF6803-4-4	13.74
FF6803-6-6	14.49
FF6803-8-8	17.36
FF6803-10-10	27.80
FF6803-12-12	32.23
FF6803-16-16	55.55
FF6803-20-20	75.78
FF6803-24-24	128.46

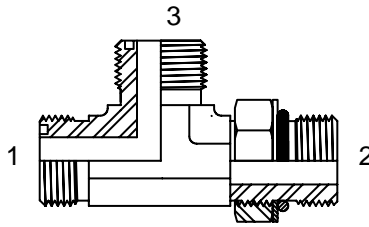

**(1)(3) MALE ORFS  
(2) ADJ. O-RING**

FF6804-4-4	12.38
FF6804-6-6	10.66
FF6804-8-8	18.64
FF6804-10-10	23.16
FF6804-12-12	38.65
FF6804-16-16	54.78
FF6804-20-20	91.68
FF6804-24-24	127.63

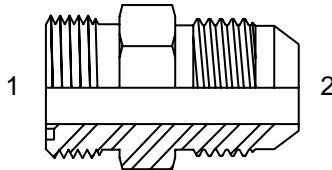

**(1) MALE ORFS  
(2) JIC MALE TUBE**

FF7403-4-4	10.98
FF7403-6-6	12.22
FF7403-8-8	13.14
FF7403-10-10	14.22
FF7403-12-12	16.39
FF7403-16-16	19.31

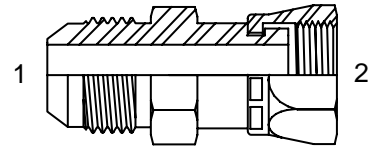

**(1) JIC MALE TUBE  
(2) ORFS FEMALE SWIVEL**

FF7504-4-4	14.22
FF7504-6-6	15.03
FF7504-8-8	19.47
FF7504-10-10	20.82
FF7504-12-12	23.63
FF7504-16-16	25.63
FF7504-20-20	36.56

METRIC AND BSP TO  
ORFS ADAPTERS ARE  
AVAILABLE. PLEASE  
CALL FOR PRICING.